

Technical Documentation

APH00545

Advantage Plus IEEE Ready | AEHH8R

Date: June 25, 2020

Dimensional Drawing

Catalogue	Model	HP	Pole	kW	Rating	Voltage	Hz	RPM
APH00545	AEHH8R	5	4	3.7	Continuous	575	60	1800

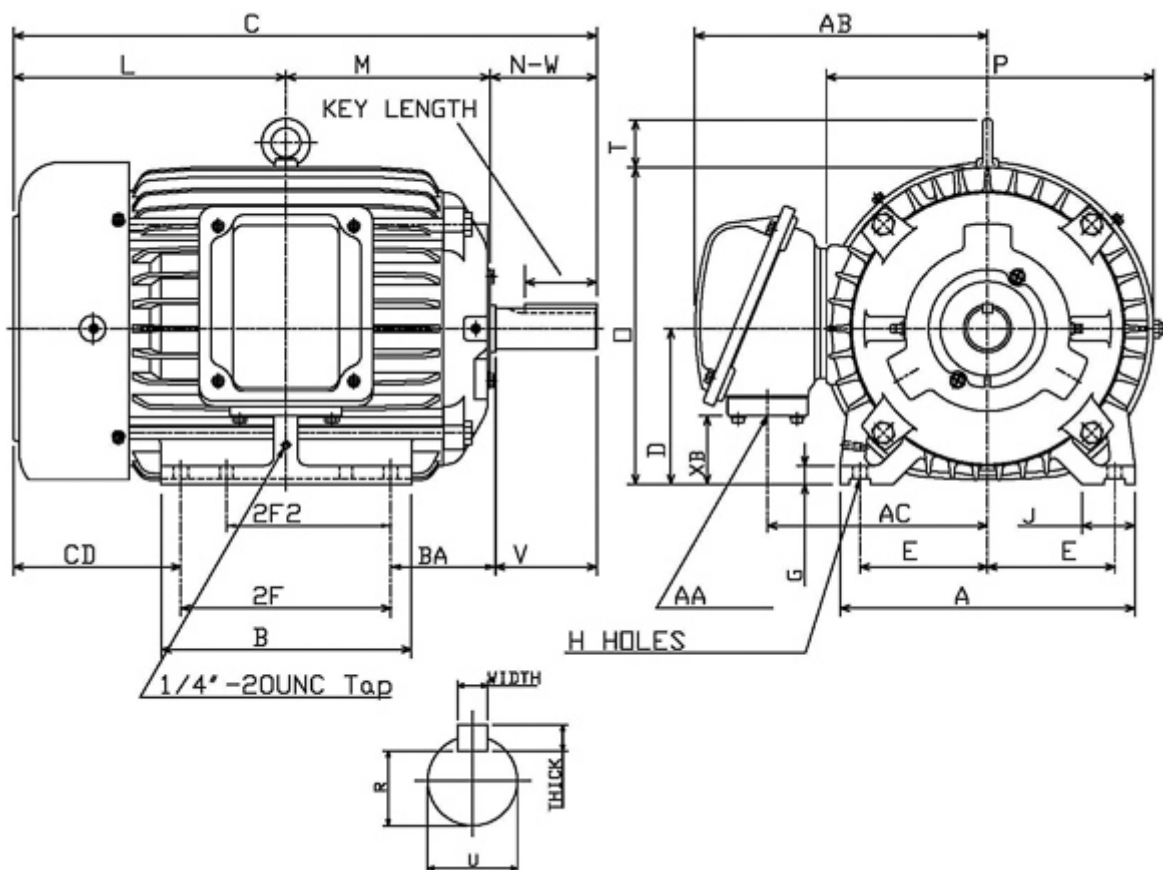

Frame Size	Mounting					A	B	C	CD	D	
	E	2F	2F2	H	BA						
184T	3.75	5.5	4.5	0.41	2.75	8.82	6.89	15.91		4.5	
G	J	K	L	M	O	P	T	Key			Keyseat
0.65	1.75		7.66	5.37	9.17	9.61	1.3	Width	Thick	Length	R
								0.25	0.25	1.78	0.986
Terminal Housing			Aux Box			C/D Flange					
AA	AB	AC	XB	AE	AX	BB	AH	AK	BD	AJ	BF
NPT3/4"	8.31	6.38	1.86								
Shaft Extension			Bearings		Approx. Weight Lbs	SPL dBA/3ft	Ins. Class	S.F.	Drive Method	Dimensions	
N-W	U	V	DE	NDE							
2.75	1.125	2.7	6306ZC3	6306ZC3	101	54	F	1.15	Direct Coupling / Belt Drive	Inches	

 MOTORS (CANADA) INC.	
	Date: June 25, 2020

Technical Data Sheet

Motor Type: AEHH8R	Catalogue No: APH00545
--------------------	------------------------

Nameplate Information

HP	Pole	RPM	Frame	Voltage	Hz	Phase
5	4	1745	184T	575	60	3
Enclosure	Ins. Class	Service Factor	Time Rating	NEMA Design	Rated Amb.	Rated Altitude
TEFC	F	1.15	Continuous	B	-40 to 40 °C	<1000 m

Typical Performance

Efficiency (%)				Power Factor (%)		
Full Load		3/4 Load	1/2 Load	Full Load	3/4 Load	1/2 Load
Nom.	Min.					
89.5	87.5	88.5	88.5	85.5	81.5	71.5
Torque				Current (A)		
Full Load (lb-ft)	Locked Rotor (% FLT)	Pull Up (% FLT)	Break Down (% FLT)	No Load	Full Load	Locked Rotor
15.04	185	140	285	1.8	4.9	37
NEMA KVA Code	Inertia (WR ²)			Safe Stall Time (s)		Noise Level Sound Press. dB(A)
	Rotor (lb-ft ²)	NEMA Load (lb-ft ²)	Max. Allowable (lb-ft ²)	Cold	Hot	
J	0.422	27.00	88.00	35	25	54

VFD Duty Information

Speed Range			VFD		S.F.
Constant Torque	Variable Torque	Constant Power	Carrier	Type	
6-60Hz	3-60Hz	60-120Hz	≤ 5 kHz	VPWM or CPWM	1.0 Only

Hazardous Locations Information

CSA Certified
Class I, Div 2, Groups B, C & D Class I, Zone 2, Groups IIB+H2, IIB & IIA
Temp Code (Sinewave / VFD)
T3C / T3C

Additional Certifications

Other Certification
Class II, Div 2, Groups F & G

Additional Information

Bearings		Approx. Weight
DE	NDE	lbs
6306ZC3	6306ZC3	101

Nameplate Drawing

Advantage Plus IEEE Ready

TYPE	AEHH8R	CAT. NO.	APH00545		
OUTPUT	5 HP 3.7 kW	FRAME	184T	TEFC	
R.P.M.	1745	POLE	4	INS.	F
VOLTS	575	PHASE	3	Hz	60
AMPS	4.9	CODE	J	S.F.	1.15
AMBIENT	40 °C	NOM. EFF. 89.5		MIN. EFF. 87.5	
BEARINGS	6306ZC3 / 6306ZC3			RATING Cont.	
SER. NO.	TBD	DESIGN	B	WT. 101 LBS	
PWM VFD DUTY	VT	CT	CP	S.F.	
	3-60Hz	6-60Hz	60-120Hz	1.0 Only	

Connection Diagram

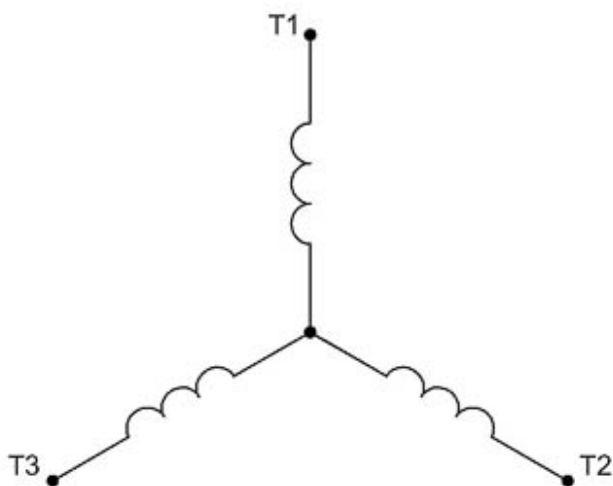

3 LEAD		SINGLE VOLTAGE			WYE
VOLTAGE	CONN.	L1	L2	L3	
-	WYE	1	2	3	

WD_3Y

Thermal Limit Curves

Motor Type: AEHH8R		Catalogue No: APH00545		Family: Advantage Plus IEEE Ready	
HP	5	Safe Stall Time		Full Load A	4.9 A
Voltage	575V 60Hz	Hot	25 s	% Inrush	757 %
RPM	1800	Cold	35 s	Locked Rotor A	37 A

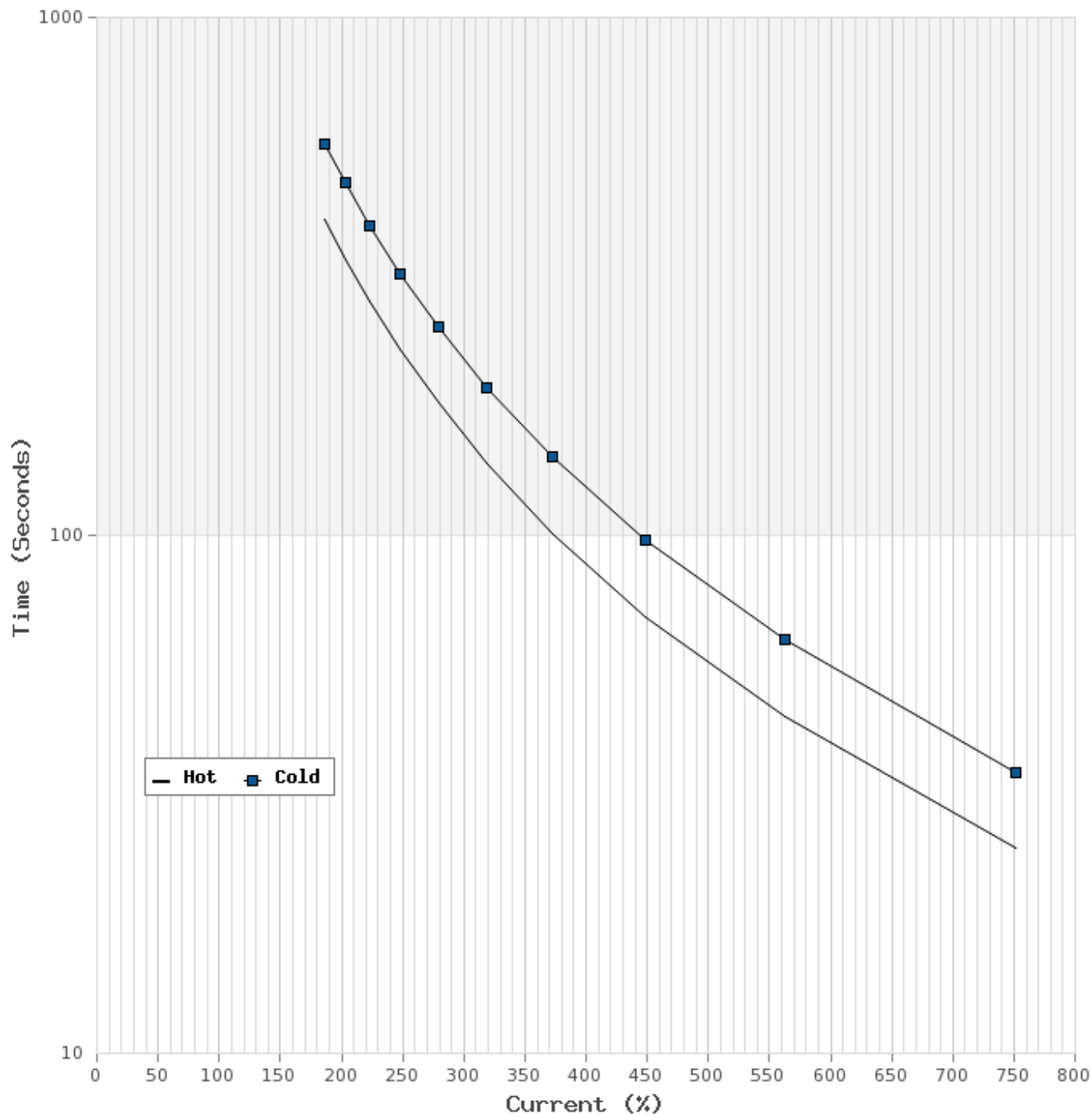

T-N and I-N Curves

Motor Type: AEHH8R		Catalogue No: APH00545		Family: Advantage Plus IEEE Ready	
HP	5	Full Load T	15.04 lb-ft	Full Load A	4.9 A
Voltage	575V 60Hz	Locked Rotor T	185 %	Locked Rotor A	37.0 A
RPM	1800	Pull Up T	140 %	Break Down T	285 %

